

Stripper Lock Tray with Hinged Cover

Rigid or semi-rigid containers of polygonal cross-section, e.g. boxes, cartons or trays, formed by folding or erecting one or more blanks made of paper by folding-up portions connected to a central panel from all sides to form a container body, e.g. of tray-like form with tongue-and-slot or like connections between sides and extensions of other sides the tongue being a part of a lateral extension of a side wall combined with a slot provided in an adjacent side wall.

Pros to Stripper Lock Trays

- Assembled and sealed by machine
- Typically shipped flat to customer, who will insert product (usually in line), convert to carton and ship to retail outlets.
- Sometimes referred to "cake box" style
- Locking dust flaps

Industries that most commonly use stripper lock trays with hinged covers

Food, Electronics, Retail Products,

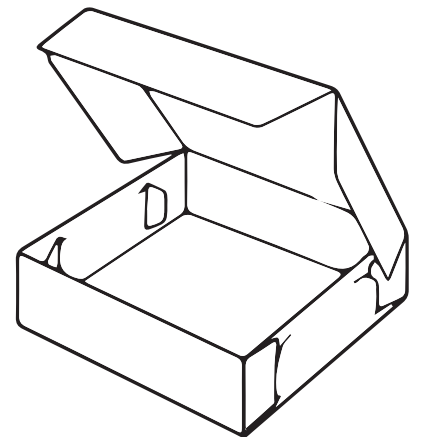
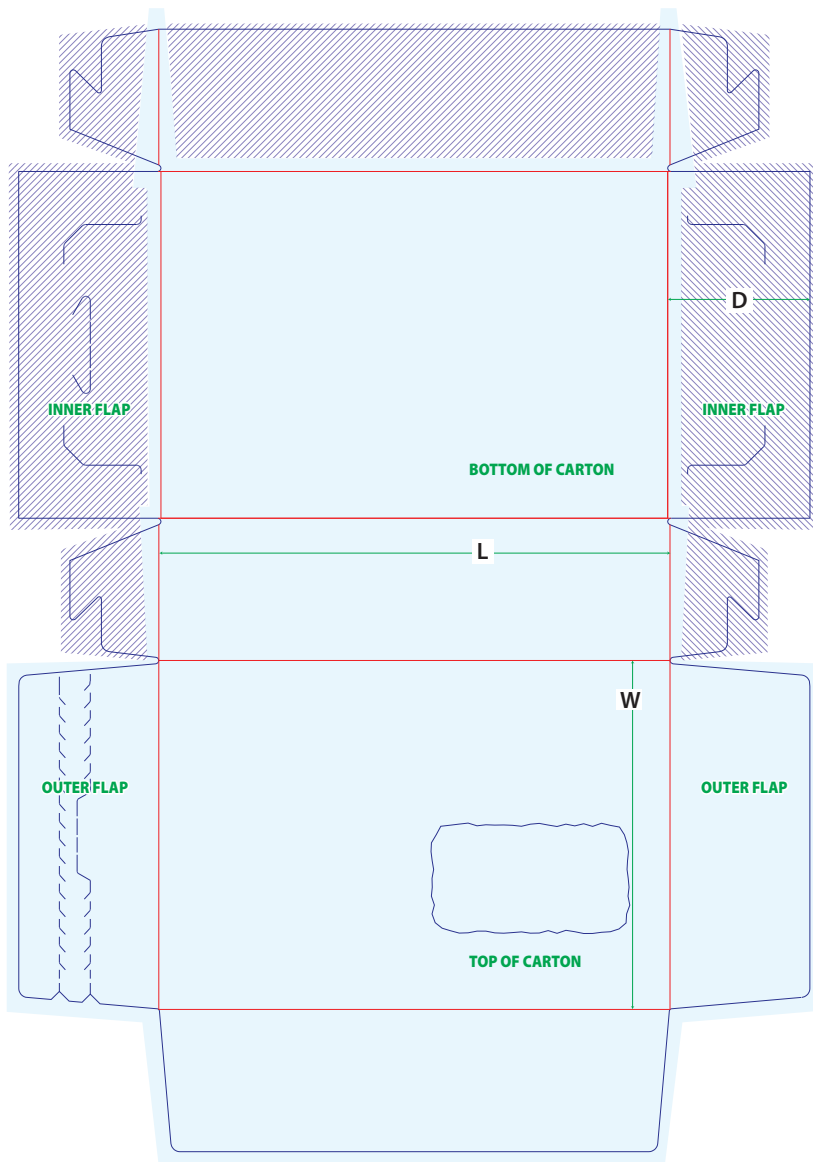

Size measured: L x W x D (options shown lock tabs, combination zipper and window)